

Dimensions  
Millimetres

Types 29, 29T, 39, 49, 59

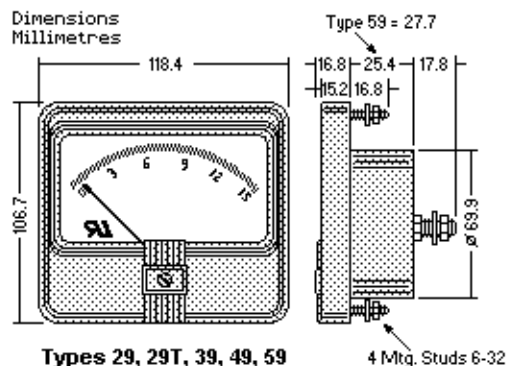
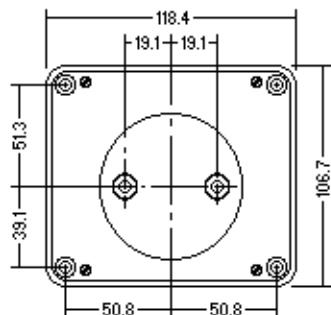

Schalttafel-Instrumente

AC Voltmeter Type 59

UL (UR) Recognized

Phenolic Cases, Glass Windows

PANEL AC VOLT METERS Type 59 (4 1/2")

Scale Length = 3.5" (88.9mm)

Range (V AC)	Catalog No.	Ref. ID.	Impedance*	Calibration / Description
0 - 3	--	08720	12 Ohms	All meters listed have iron-vane type meter movement, calibrated at 60 Hz with $\pm 1\%$ deviation.
0 - 15	--	08750	300	
0 - 25	--	08760	833	
0 - 50	--	08770	3.333	
0 - 100	--	08780	16.166	
0 - 150	55F181	08790	25.000	
0 - 300	55F191	08810	50.000	
0 - 500	55F192	08820	83.333	

\*at 60 Hz