

USA / Canada - Industrial Grade Weatherproof Covers

Industrial Grade Weatherproof Covers

SPECIFICATIONS

- Unbreakable Glass-Filled Grey Polycarbonate Construction
- Stainless Steel Mounting Screws
- Covers Comply with 2005 NEC Section 406.8(A) and 406.8(B)(2).
- Molded-In Label Area
- Lockable "Bullnose" for OSHA Locktag/Tagout Compliance
- UL Listed, CSA Certified



Catalog No.	Description	Weight/each	VPE/Pack	EDP No.
WPG-1	Weatherproof Cover for Flanged Inlets and Outlets with 1.96" (49.8mm) Diameter max. Opening to Accommodate 15A and 20A Straight Blade, and 15A Locking, Grey	101 g net.	100/10	114476
WPG-2	Weatherproof Cover for Flanged Inlets and Outlets with 2.32" (58.9mm) Diameter max. Opening to Accommodate 20A and 30A Locking, Grey	96 g net.	100/10	114508



FEATURES

- Unbreakable glass-filled polycarbonate construction to withstand years of job site abuse and harsh environmental exposure. Stainless steel mounting screws also resist corrosion.
- Covers comply with 2005 NEC Section 406.8(A) and 406.8(B)(2).
- Molded-in label area (2.8 sq. in.) for pre-printed or handwritten labels for identification of circuits, ratings, and other application data.
- Covers have lockable "bullnose" for OSHA locktag/tagout compliance.
- Covers fit all competitive inlets and outlets.
- Pre-attached gaskets for easy installation and tight seal to panel or weatherproof box – with no misaligned or collapsed gaskets.
- Tamper-proof hinge features permanent, locked-in pins for added security.

UL Listed and CSA Certified flush device cover plate, wet location only when cover closed and damp locations.

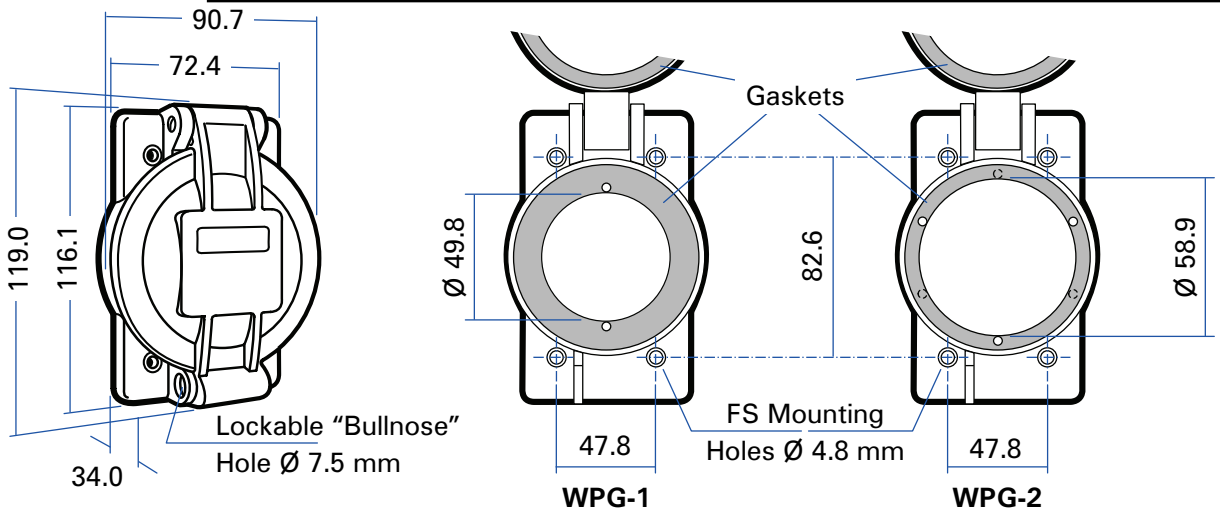

Technical Data are Subject to Change without Notice. Dimensions in mm.