

## Type 4 miniature light curtain, 30 mm / 1.18 in resolution

*FF-LS30 Series*

Designed for the protection of operators work stations

### FEATURES

- Meets applicable parts of US OSHA 29 CFR 1910.217, 1910.212 and ANSI B11.1, B11.2, B11.19 1990 and RIA 15.06 regulations for Control Reliability
- EC type examination certificate granted by the TÜV
- Designed in compliance with the IEC/EN 61496 - parts 1 & 2 for Type 4 Electrosensitive Protective Equipment (permanent self-checking equipment)
- Through-scan small profile sensing unit with separate control unit
- Minimum object detection capability:  $\varnothing$ 30 mm / 1.18 in suitable for hands detection
- Scanning range: from 0,2 m up to 3,5 m / 0.65 ft to 11.48 ft
- Protection heights: from 236 mm up to 1804 mm / 9.29 in up to 71.07 in
- Global response time: less than 50 ms
- Power supply voltage: 24 Vac/dc
- Outputs: 2 guided contacts safety relays
- Test input
- Automatic restart or start & restart interlock
- Sealing: IP 65 (sensing units and control unit)
- Immunity to ambient light: 50 000 Lux max.

### TYPICAL APPLICATIONS

- Paper-cutting machines
- Pick-and-place robots
- Light electronic assembling machines
- Good lifts
- Small carousels

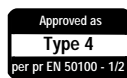

The FF-LS equipment is an infrared multibeam device designed to protect operators working on dangerous machines. The FF-LS equipment features are ideal for the protection of work stations on small machines such as paper-cutting machines or pick-and-place robots.

The permanent self-checking electronic process is based upon a microprocessor technology and meets the requirement of the IEC/EN 61496- parts 1 & 2 European standards for Type 4 electrosensitive protective equipment.

It has been examined by the TÜV who granted the EC type examination certificate.

The equipment consist of a pair of sensing units connected to a separate control unit via a RS-485 connection.

Each sensing unit is made of a row of emitting circuits alternating with receiving circuits. These circuits are housed in an extremely small aluminium extruded profile: the cross section is only 12 mm x 19,7 mm / 0.47 in x 0.77 in.

The two sensors are matched to each other by individual coding to reduce risk of cross talk with other light curtains and to improve immunity to welding splashes.

The control unit supplies the sensing units, controls the correct operation of the scanning circuits and transmits the resulting commands to the machine control circuitry through its two relay outputs.

The equipment can operate according to two different mode: the automatic mode, the start & restart interlock mode.

In addition, the control unit is featured with a test input to trigger the output relays switching and thus check the correct operation of the final switching devices whenever needed. In case of failure, the control unit provides optical and acoustic signals to ease failure diagnostic.

### **WARNING**

#### MISUSE OF DOCUMENTATION

- The information presented in this product sheet (or catalogue) is for reference only. DO NOT USE this document as system installation information.
- Complete installation, operation and maintenance information is provided in the instructions supplied with each product.

Failure to comply with these instructions could result in death or serious injury.

## FF-LS30

- Type 4 according to IEC/EN 61496 - parts 1 & 2
- $\varnothing 30$  mm / 1.18 in object detection capability
- Reduced dimensions (12 mm x 19,7 mm / 0.47 in x 0.77 in cross section)

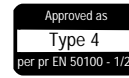
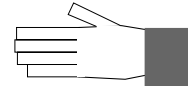

Dimensions in millimeters / inches, meters / feet, weights in kg / lbs

Specifications	Supply voltage	22 to 30 Vdc or 18 to 25 Vac
	Current consumption	< 300mA
	Output switching capacity	Main out 1 & out 2: 4 A/250 Vac/Lamp: 4 A/42 V
	Material	Sensor: Aluminium profile / Control unit: Polycarbonate
	Housing Size	Sensors: 12 mm x 19,7 mm x PH mm / 0.47 in x 0.77 in x PH in Control unit: 60 mm x 160 mm x 240 mm / 2.36 in x 6.30 in x 9.45 in
	Emission	Modulated infrared light (880 nm)
	Resolution	$\varnothing 30$ mm / 1.18 in
	Alignment tolerance	According to IEC/EN 61496 - 2 standard
	Operating temperature	0 °C to 55° C / 32 °F to 131° F
	Sealing	Sensors and control unit: IP 65
	Electromagnetic immunity	According to IEC 801-4: level IV/According to IEC 801-3 level III
	Light immunity	50 000 Lux
	Status indicators	Lamps to be connected to outputs available on control units
	Range	0,2 m to 3,5 m / 0.65 ft to 11.48 ft
	Electrical wiring (delivered with the unit)	Sensors: RS-485 cable / Pre-wired connectors (10 m / 32.8 ft) Control unit: Screw terminal

### Ordering information (1)

FF-LS-□□□28□□□□2

Number of beams	Model	Protection height (PH) (mm / in)
08	0236	236 / 09.29
16	0460	460 / 18.12
24	0684	684 / 26.94
32	0908	908 / 35.77
40	1132	1132 / 44.60
48	1356	1356 / 53.42
56	1580	1580 / 62.25
64	1804	1804 / 71.07

### Notes:

(1) Each reference corresponds to the delivery of a complete set: A/B sensors, control unit, 2 RS-485 cables (pre-wired 10 m / 32.8 ft), brackets, 8 cable glands and a  $\varnothing 30$  mm / 1.18 in test rod.

(2) Power supply: The use of one of these supplies brings the galvanic isolation which is necessary for the system to be in compliance with IEC/EN 61496-1 standard.

FF-LSZUS0605 (230 Vac / 24 Vdc)

FF-LSZUS0606 (115 Vac / 24 Vdc)

These power supplies must be ordered separately.

(3) Control unit and sensors.

Sensors A and B have the same dimensions.

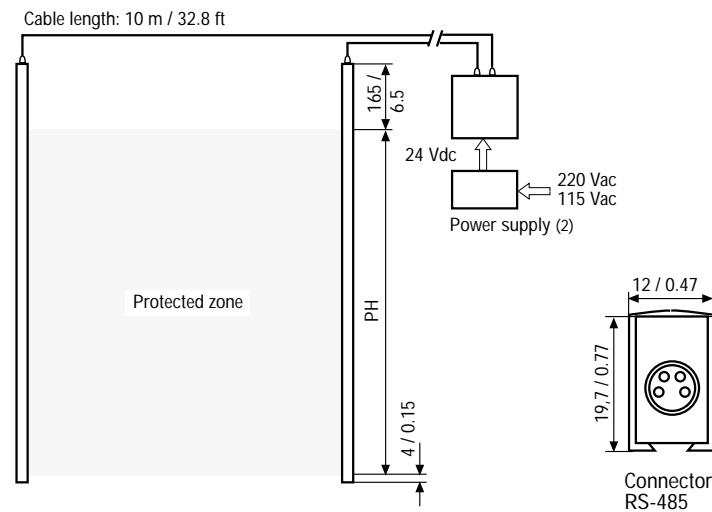

Control unit (4 mounting M4 holes) Power supplies (2)

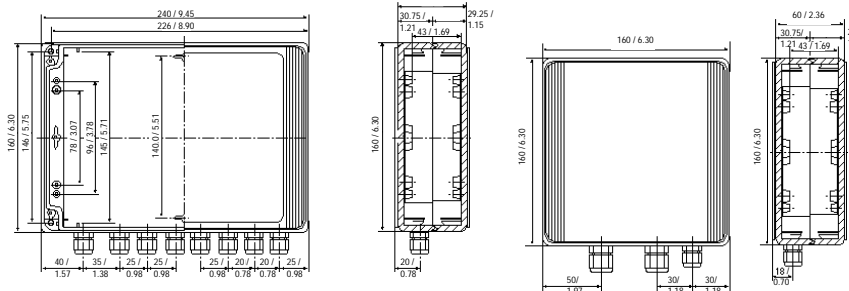

Nominal Protection Height	mm / in	PH	236 / 9.29	460 / 18.12	684 / 26.94	908 / 35.77	1132 / 44.60	1356 / 53.42	1580 / 62.25	1804 / 71.07
Number of beams			8	16	24	32	40	48	56	64
Response time		t1	< 50 ms	< 50 ms	< 50 ms	< 50 ms	< 50 ms	< 50 ms	< 50 ms	< 50 ms
Weight of the device (3)		kg / lbs	1,75 / 3.85	1,86 / 4.1	1,97 / 4.34	2,08 / 4.58	2,19 / 4.82	2,30 / 5.07	2,41 / 5.31	2,52 / 5.55

## Safety distance

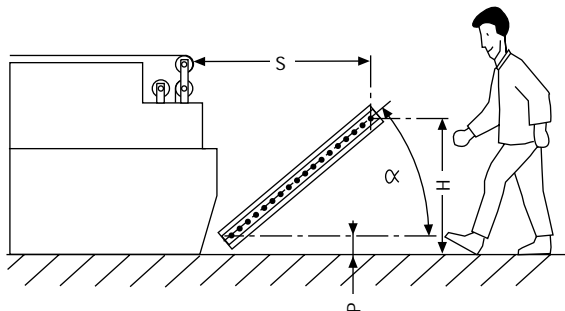
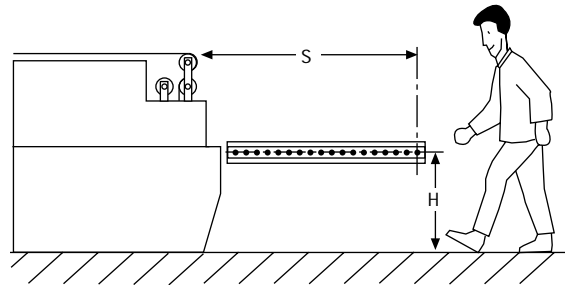
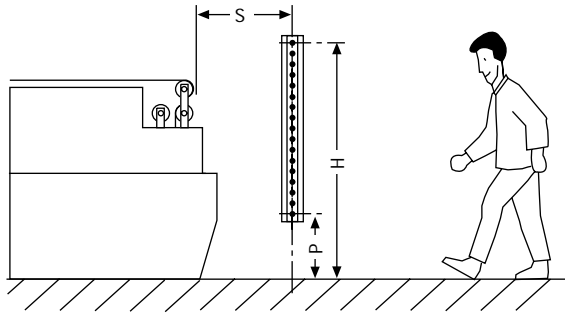

- S: Minimum safety distance (mm / in)
- t1: Response time of the light curtain (s)
- t2: Stopping time of the equipment guarded by the light curtain, including all mechanical, electromechanical and electronic parts (s)
- H: Height of the detection zone above the floor (mm / in)

The safety distance between the protection field and the dangerous zone should be large enough to ensure that if the protection field is entered, the dangerous zone cannot be reached before the hazardous movement is arrested. For the safety distance, the following formula applies:

### • Normal approach

Europe (EN 999)

$$S \geq 2000 (t1 + t2) + 128 \text{ (mm), with } S \geq 100 \text{ mm}$$

$$\text{(or } S \geq 78.8 (t1 + t2) + 5 \text{ (in), with } S \geq 3.9 \text{ in)}$$

If the result of this calculation is greater or equal to 500 mm / 19.7 in, then use the following formula:

$$S \geq 1600 (t1 + t2 + 128 \text{ (mm), with } S \geq 500 \text{ mm}$$

$$\text{(or } S \geq 63 (t1 + t2) + 5 \text{ (in), with } S \geq 19.7 \text{ in)}$$

US (OSHA 29 CFR 1910.217, ANSI B11.19 1990)

$$Ds \geq 63 (t1 + t2) + 3.08 \text{ (in) } Ds = S$$

### • Parallel approach

Europe (EN 999)

$$S \geq 1600 (t1 + t2) + (1200 - 0.5H) \text{ (mm)}$$

$$\text{where } (1200 - 0.4H) \geq 850 \text{ mm}$$

$$\text{(or } S \geq 63 (t1 + t2) + 47.3 - 0.4H0 \text{ (in)}$$

$$\text{where } (47.3 - 0.4) \geq 33.5 \text{ in)}$$

If H is greater than 300 mm / 11.82 in, the risk of access from below must be taken into account. For this barrier, the minimum height allowed is H min. = 0 mm and the maximum height allowed is H max. = 1 000 mm / 39.4 in.

### • Angled approach

Europe (EN 999)

$$30^\circ < \alpha < 90^\circ$$

If the angle is greater than 30°, the approach should be considered as normal, and one of the above-mentioned formulas should be used.

$$0^\circ < \alpha \leq 30^\circ$$

If the angle is less than or equal to 30°, the approach should be considered as parallel and one of the above-mentioned formulas should be used. In this case the minimum height allowed is P min. = 0 mm and the max. height allowed is H = 1 000 mm / 39.4 in max. However, if P > 300 mm / 11.82 in, the risk of inadvertent access from below must be taken into account.

## Connection diagram

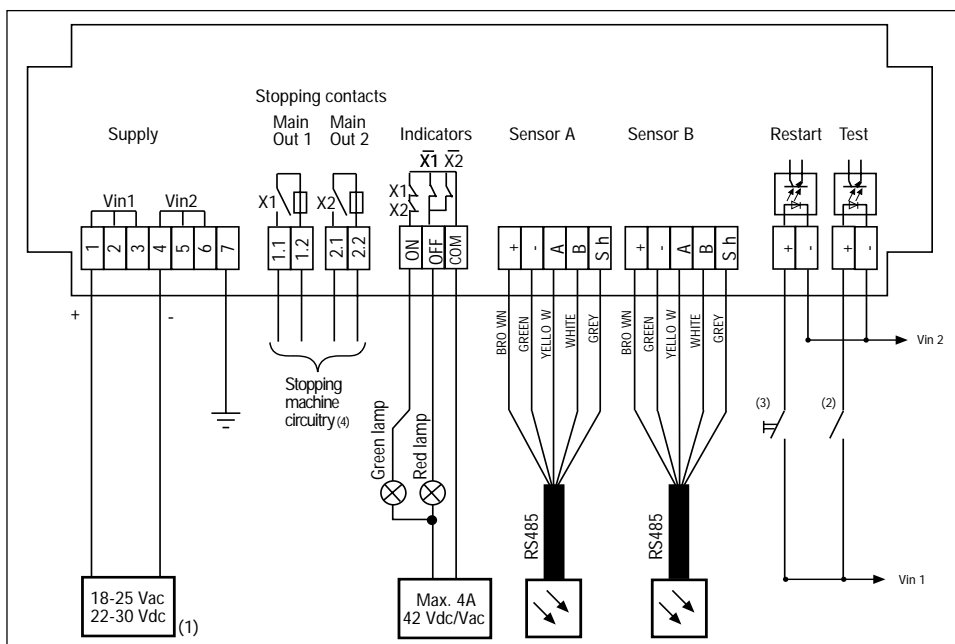

(1) - Supply (to be ordered separately): The use of one of these supplies brings the galvanic isolation which is necessary to the system for a use conform to IEC/EN 61496 - 1 standard.

FF-LSZUS0605 (230 Vac / 24 Vdc),  
FF-LSZUS0606 (115 Vac / 24 Vdc)

(2) - Test duration: The contact must be closed during 100 ms as a minimum.

(3) - The push-button must remain closed during 200 ms at least. It takes 500 ms for the system to restart after releasing the push-button.

(4) - If additional contacts are needed or if the switching capacity must be increased, use the connection diagram given or an example.

Connection diagram example: Start/Restart interlock/Final Switching Device (FSD) monitoring  
(please refer to EN 954 for electrical interface)

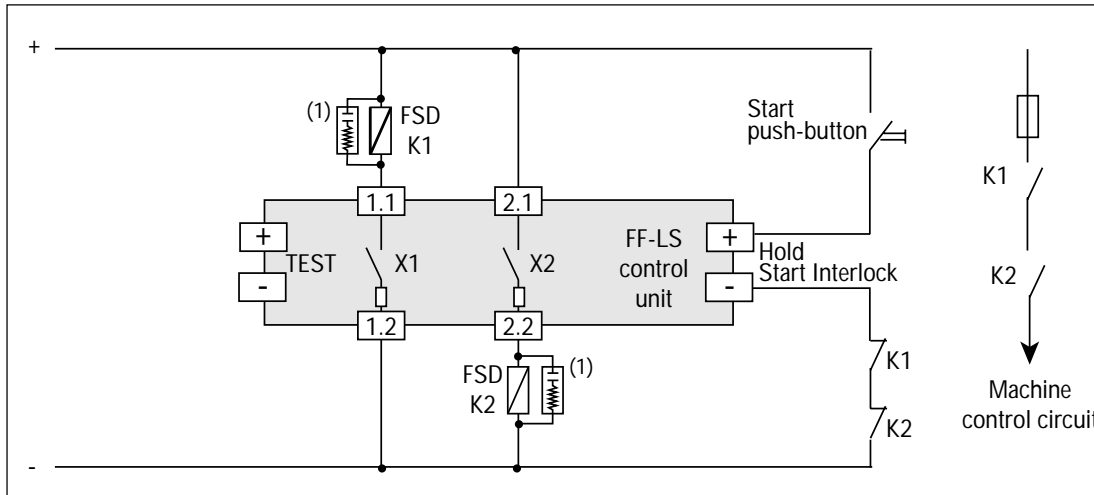

(1) RC (220 Ω + 22 μF) for ac interface (or varistors for dc interfaces) increases the life of contacts and improves electrical noise immunity.

### Accessories

FF-LSZKA0611: Connecting cable

One 10 m / 32.8 ft RS485 prewired cable for the connection of one sensing unit to the control unit.

FF-LSZMS660

Straight bracket

Kit of 2 straight brackets for an installation parallel to the sliding rail.

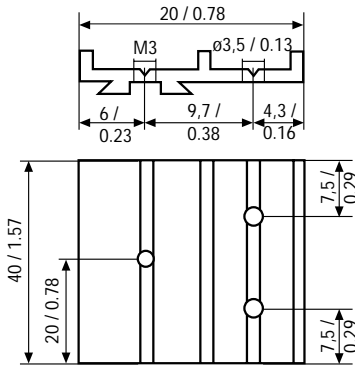

FF-LSZMS690

Right-angle bracket

Kit of 2 right-angle brackets for an installation perpendicular to the sliding rail.

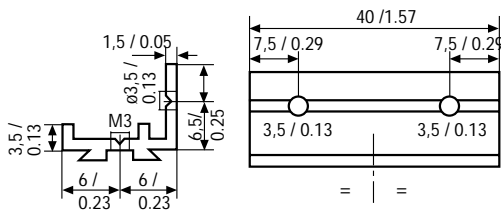

Note: All FF-LS equipment is delivered with both types of brackets. The number of brackets available allows to fix one bracket every 500 mm / 19.7 in along the profile.

### Examples

### Example of installation

For a correct installation, brackets must be fixed on a plain base in order to avoid profile deformation.

