

## Electrical Accessories Low-Voltage Switching Components

### Application

Low-Voltage Remote Control Products consist of reliable, field-tested switching circuitry that provide central or local control of lighting loads throughout a building. These are best applied in institutions, schools, commercial buildings, warehouses and other installations where the ON-OFF switching of lighting is widely dispersed throughout the structures.

### Important:

Low-Voltage Switching Components are specifically designed for switching incandescent and fluorescent lighting (non-HID) loads.

Low-Voltage Switching Components are not to be used with any components supplied by other manufacturers. Mis-application or improper use may void product warranties.

### Basic Wiring Diagram

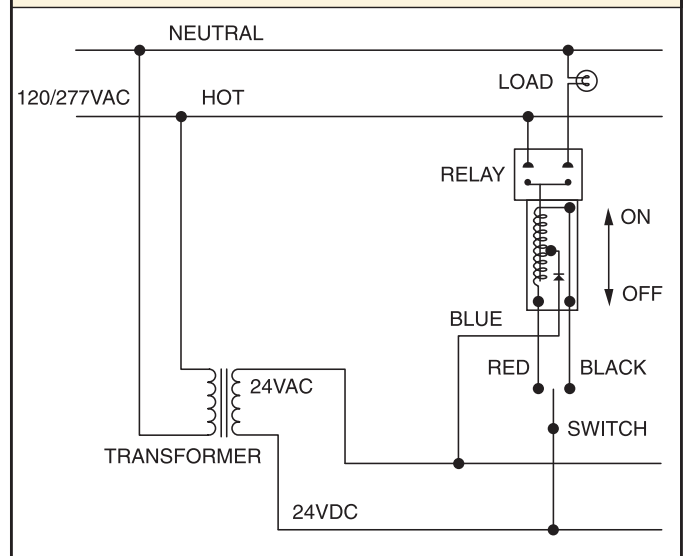

### The ABCs of Low-Voltage Wiring and Components

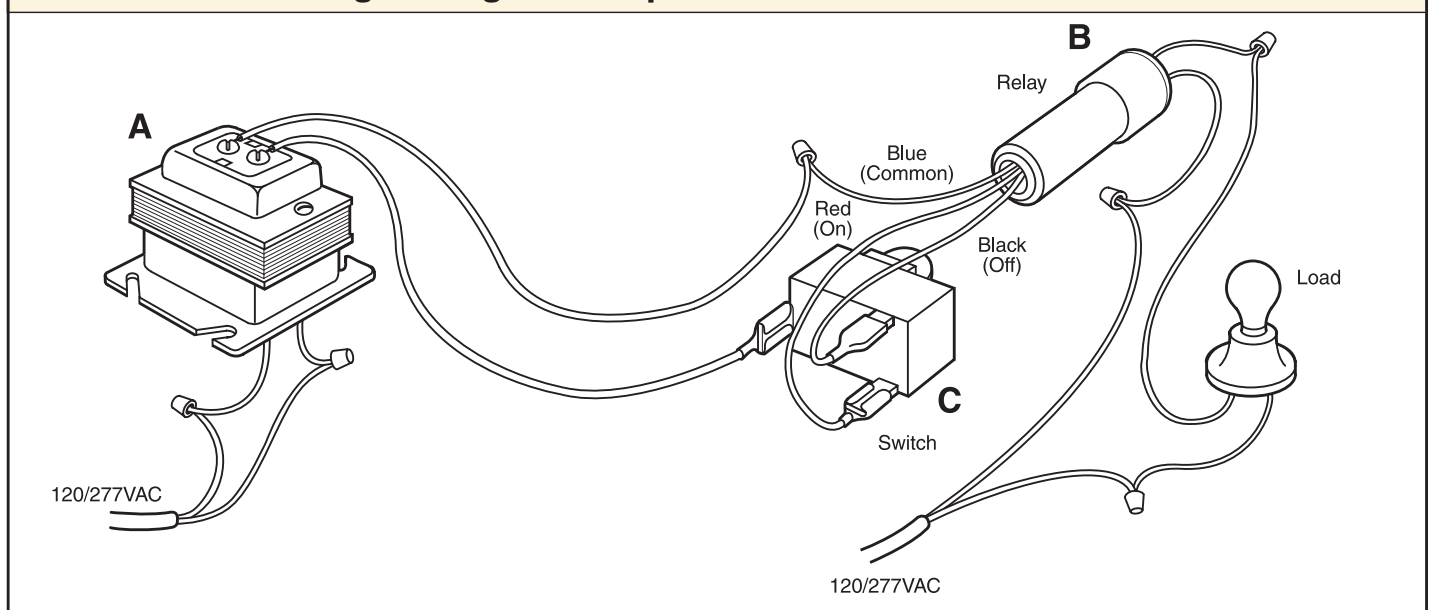

The low-voltage system differs from conventional switch wiring by actuating relays through the use of momentary contact switches. This type of switching utilizes a transformer to provide safe low-voltage current to control line voltage circuits. The wiring of lights and other electrical loads is installed in the conventional manner.

The above illustration simplifies a low-voltage circuit with its basic components:

**A. Transformer** – Converts line voltage to low-voltage. All low-voltage components operate using 24 volts furnished by the step-down transformer. Secondary output is 3-12A.

**B. Relay** – The magnetic relay switches line voltage. A momentary 24 volt pulse energizes the “ON” or “OFF” coils to make or break line voltage contacts.

**C. Switches** – Switches are momentary contact type used to energize either the “ON” or “OFF” coils of a relay. Momentary contact switches are normally open, single pole, double throw.

All devices listed on this page conform to NEMA WD-1 and WD-6.

### Features

- Mount in standard 1/2" KO through noise suppressing nylon ring.
- Maximum ambient temp: 140°F (60°C).
- Insulated flame retardant nylon shell.
- Prestripped 5-1/2" (140mm) #22 AWG leads for easy wiring.
- Split coil design energizes ON coil to close line contacts, and OFF coil to open contacts.
- Can be mounted in any position.
- Operates on momentary impulse.
- Draws .520 mA.

Catalog Number	Rating A. V.	3rd Party Compliance	
		UL Listed	CSA Listed
<b>Magnetic Latching Relay, 24V/24VDC Control</b>			
1070-B	20 120/277V 20 347V	•	•

CSA listed for 347V.

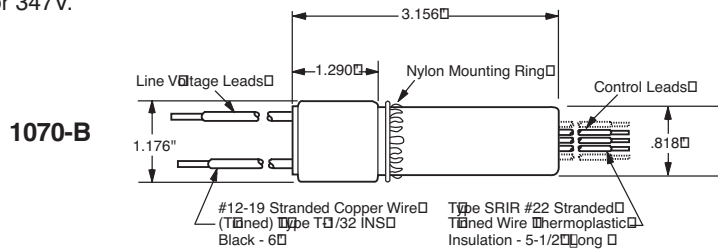

### Features

- Available in Despard® interchangeable and heavy-duty toggle versions.
- Side wired screw terminals.
- Heavy-duty toggles recommended where low-voltage switches must match conventional switches.

Catalog Number	Color	Rating A. V.	Description
<b>Momentary Contact Switches</b>			
1091-I	Ivory	3 24 AC/DC	Despard Interchangeable
1091-W	White	3 24 AC/DC	Despard Interchangeable
1091	Brown	3 24 AC/DC	Despard Interchangeable
1091-GRY	Gray	3 24 AC/DC	Despard Interchangeable
1091-KGRY	Gray	3 24 AC/DC	Despard Interchangeable, Key-Locking
1050-K			Key only for Despard Locking Switch
1081-I	Ivory	3 24 AC/DC	Heavy-duty Toggle
1081-W	White	3 24 AC/DC	Heavy-duty Toggle
1081	Brown	3 24 AC/DC	Heavy-duty Toggle
1081-GRY	Gray	3 24 AC/DC	Heavy-duty Toggle
1081-KGRY	Gray	3 24 AC/DC	Heavy-duty Key-Locking
500-K			Key only for Heavy-duty Locking Switch

**Note:** When installing low-voltage control wiring, wires should not be bundled or run in parallel with line voltage wires.

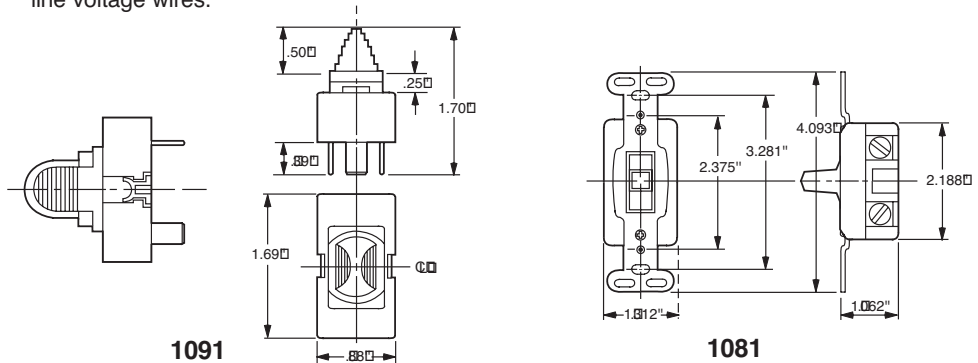

All devices listed on this page conform to NEMA WD-1 and WD-6.

### Features

- 100% HIPOT tested primary and secondary.
- Base fits 4 Screw box.
- Built-in overload protection.

Catalog Number	VA Rating	Primary Volts	Secondary Volts	Secondary Output
<b>Transformers</b>				
1038	75 VA	120V	24V	3.12A
1039	75 VA	277V	24V	3.12A

A 75VA transformer can drive a maximum of 7 relays simultaneously. However, the length of a wire run as well as the size of the wire itself have an effect on a transformer's output capability.

The following tables will be useful in selecting the proper wire size and length of wire runs.

### 75VA transformer (1038 or 1039) switch leg-length of run in feet (2 wires):

No. of Relays in Parallel	#12 Wire	#14 Wire	#16 Wire	#18 Wire	#20 Wire	#22 Wire
1	3000'	2000'	1200'	750'	500'	300'
2	1500'	1000'	600'	375'	250'	150'
3	1000'	650'	400'	250'	160'	100'
4	750'	500'	300'	180'	125'	75'
5	600'	400'	240'	150'	100'	60'
6	500'	330'	200'	125'	80'	50'
7	420'	280'	170'	100'	70'	40'

### Notes:

Relays in Parallel – Relays so wired will **all** be activated by **any** switch in the circuit. If more than one transformer is used, the load should be divided between transformers.

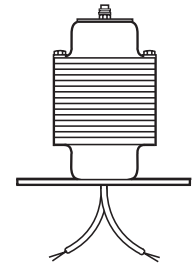
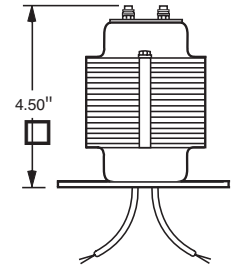
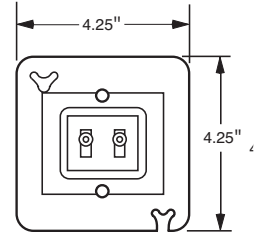

1038

All devices listed on this page conform to NEMA WD-1 and WD-6.

To learn more about B-I-A please visit us at our  
WEB site: [www.BiaGmbH.com](http://www.BiaGmbH.com)

